



High-Precision Stark Effect Measurements and Laser Cooling of Lead in an Atomic Beam

Charlene Peng*, John H. Lacy, Elena Deegan-Krause, Benjamin L. Augenbraun, and P. K. Majumder

Department of Physics, Williams College, Williamstown, MA 01267 USA

* → Physics Dept., Harvard U.

POSTDOC POSITION AVAILABLE!

SCAN QR CODE →



Work supported by NSF grant #2513404

Background

- There are few high-precision atomic structure measurements of heavy, multivalence atoms.
- Recent work:**
 - Transition amplitude (TA) measurements in Pb – providing tests of *ab initio* wavefunction calculations relevant to symmetry-violating fundamental interactions.
 - Transition isotope shift (TIS) and hyperfine structure (HFS) measurements – providing information about nuclear structure and wavefunction properties close to the nucleus. (See talk on Thur. 8.12 am, session N12)
- Current work:**
 - Stark measurements: further tests of *ab initio* theory.
 - Experimental groundwork for Pb-based molecules for eEDM searches – requires laser cooling of Pb.

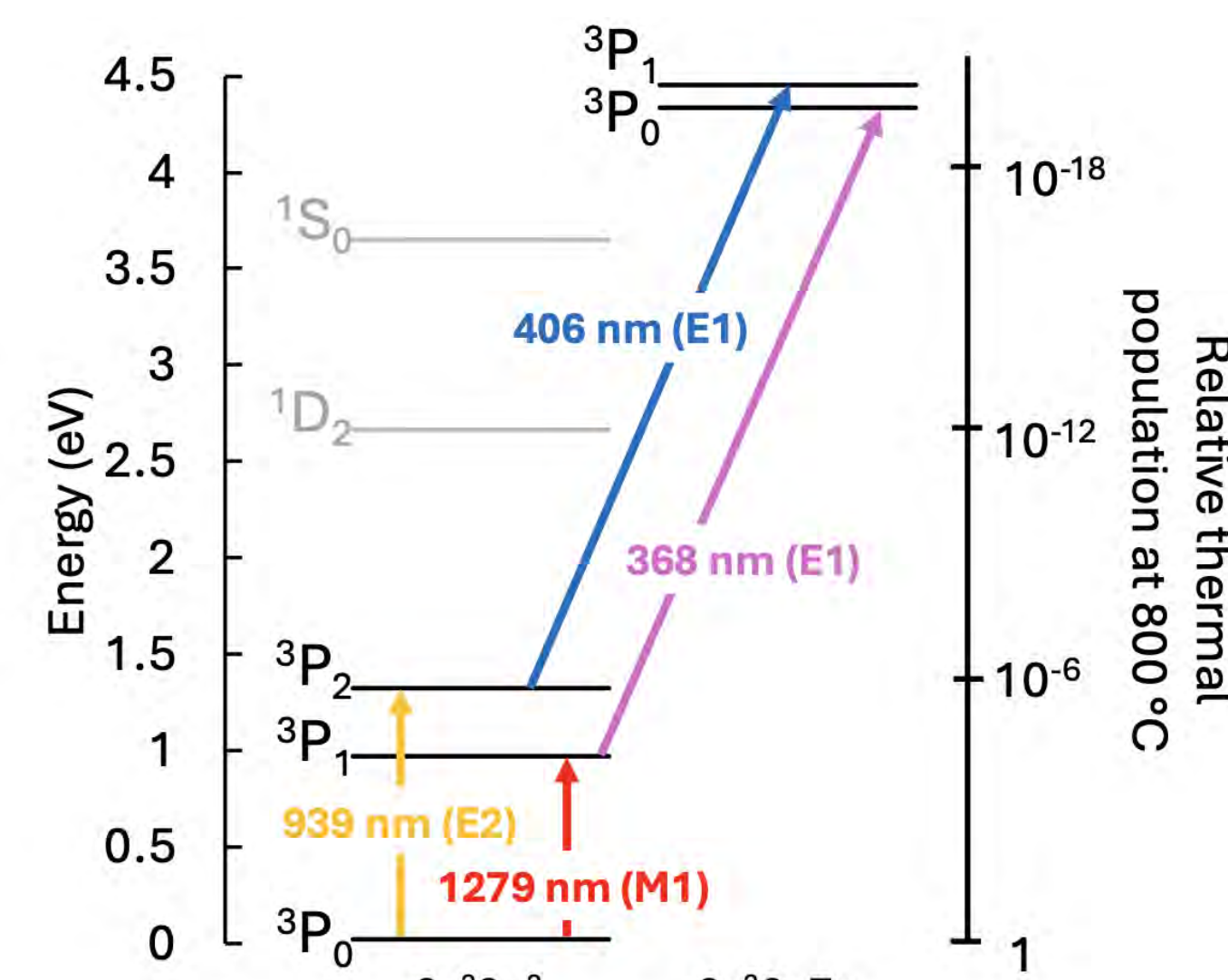

Recent work – Transition amplitude measurements

Faraday rotation spectroscopy

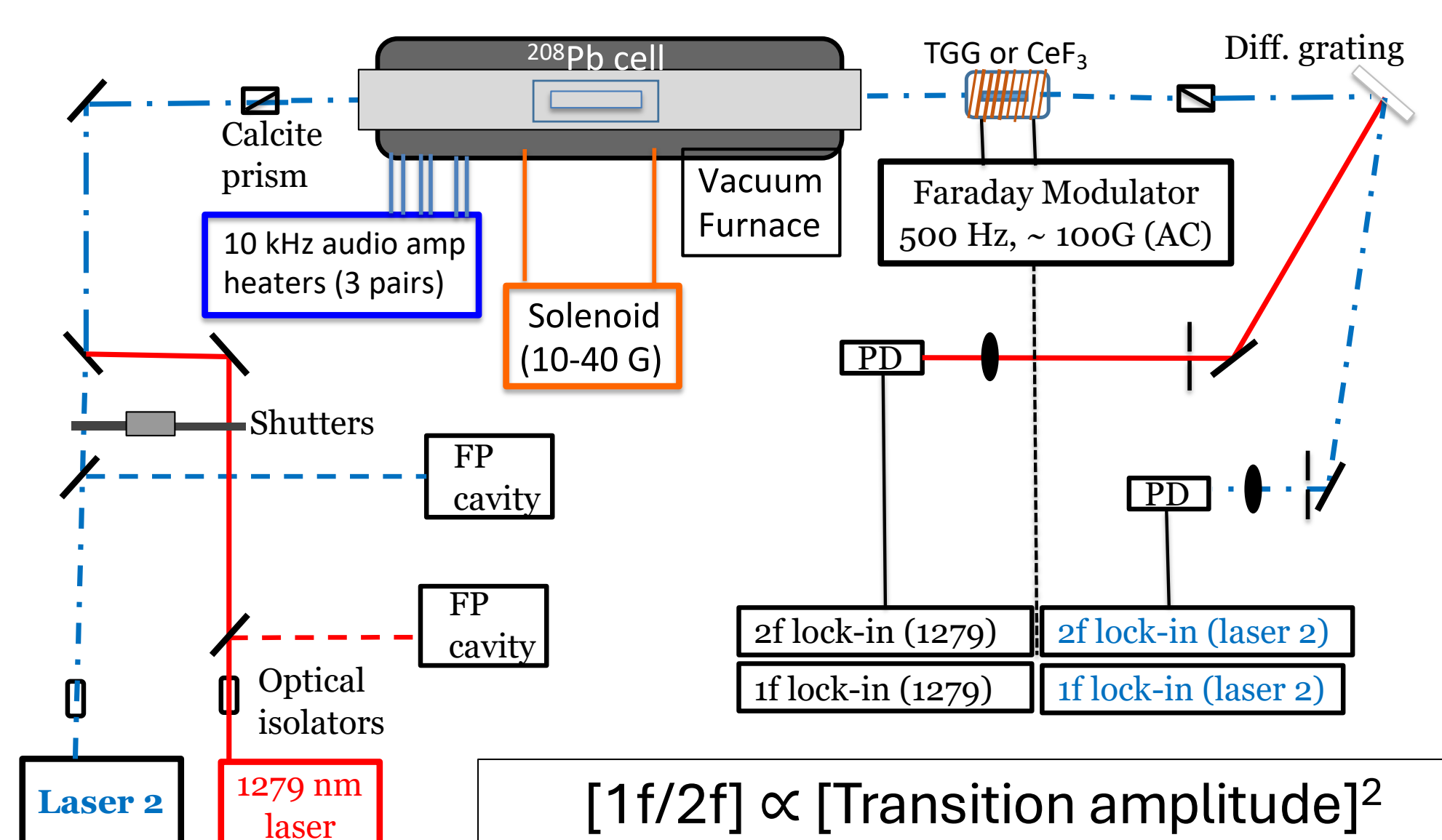

- Recent TA measurements in ^{208}Pb using Faraday rotation spectroscopy.
- Excellent signal-to-noise ratio (mrad level signals measured with μrad level resolution) allowing for TA measurements at the sub-1% level.
- Latest results and *ab initio* theory values are summarized in the table.

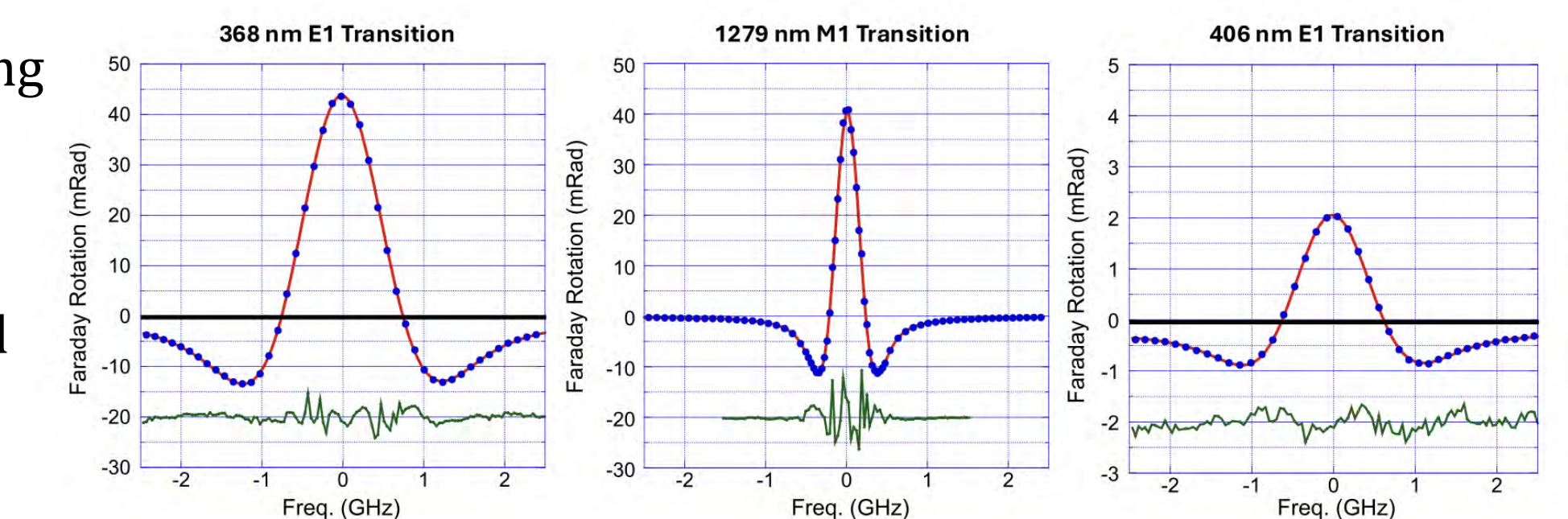

Representative optical rotation spectra at 800 °C. The precisely known 1279 nm M1 transition serves as a reference.

Transition	Our measurement (a.u.)	Theory (Porsev and Safronova) (a.u.)
939 nm (E2)	8.91(9)†	8.88(5)
368 nm (E1)	1.90(1)‡	1.92(6)
406 nm (E1)	3.01(2)‡	2.99(9)

†Phys. Rev. A 100, 052506 (2019)
‡Phys. Rev. A, 111, 042808 (2025)

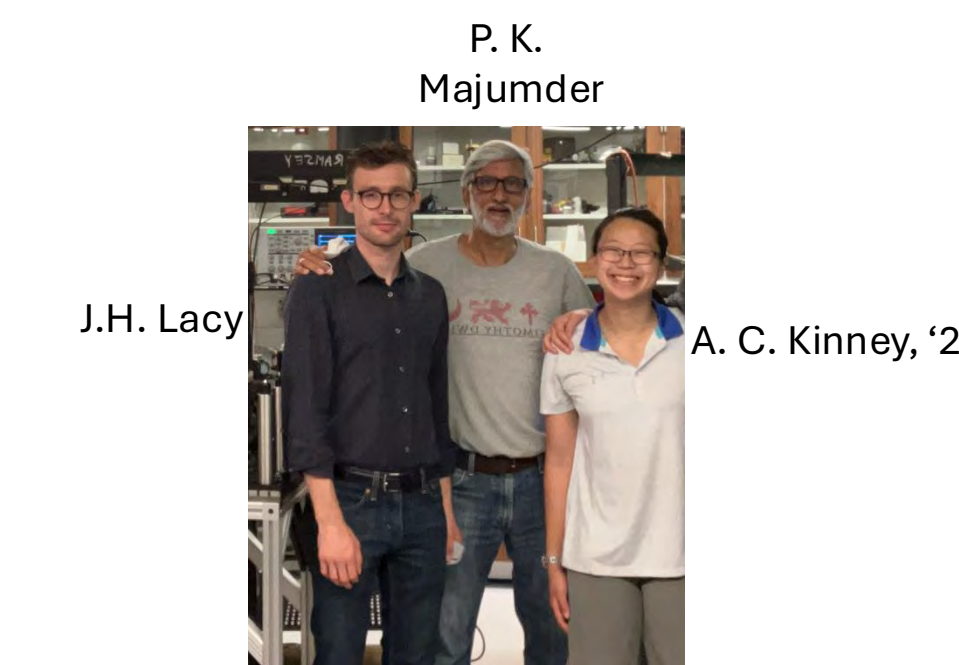

Current work – Stark Effect Measurements

- Building on from previous atomic beam work in thallium and indium, we are modifying an atomic beam apparatus for Pb. Our experimental route is structured as follows:
 - Step 1:** Static polarizability measurements associated with the $(6p^2)^3P_1 \rightarrow (6p7s)^3P_0$ E1 transition at 368 nm. Shifts of ~ 40 MHz are expected in a 20 kV/cm field based on theoretical polarizability values.
 - Step 2:** Stark-induced amplitude of the $(6p^2)^3P_0 \rightarrow ^3P_1$ M1 transition at 1279 nm (experimental apparatus shown right).
 - Step 3:** Demonstration of transverse laser cooling of Pb – relevant to eEDM searches with Pb-based molecules.

Step 1: static polarizability measurements

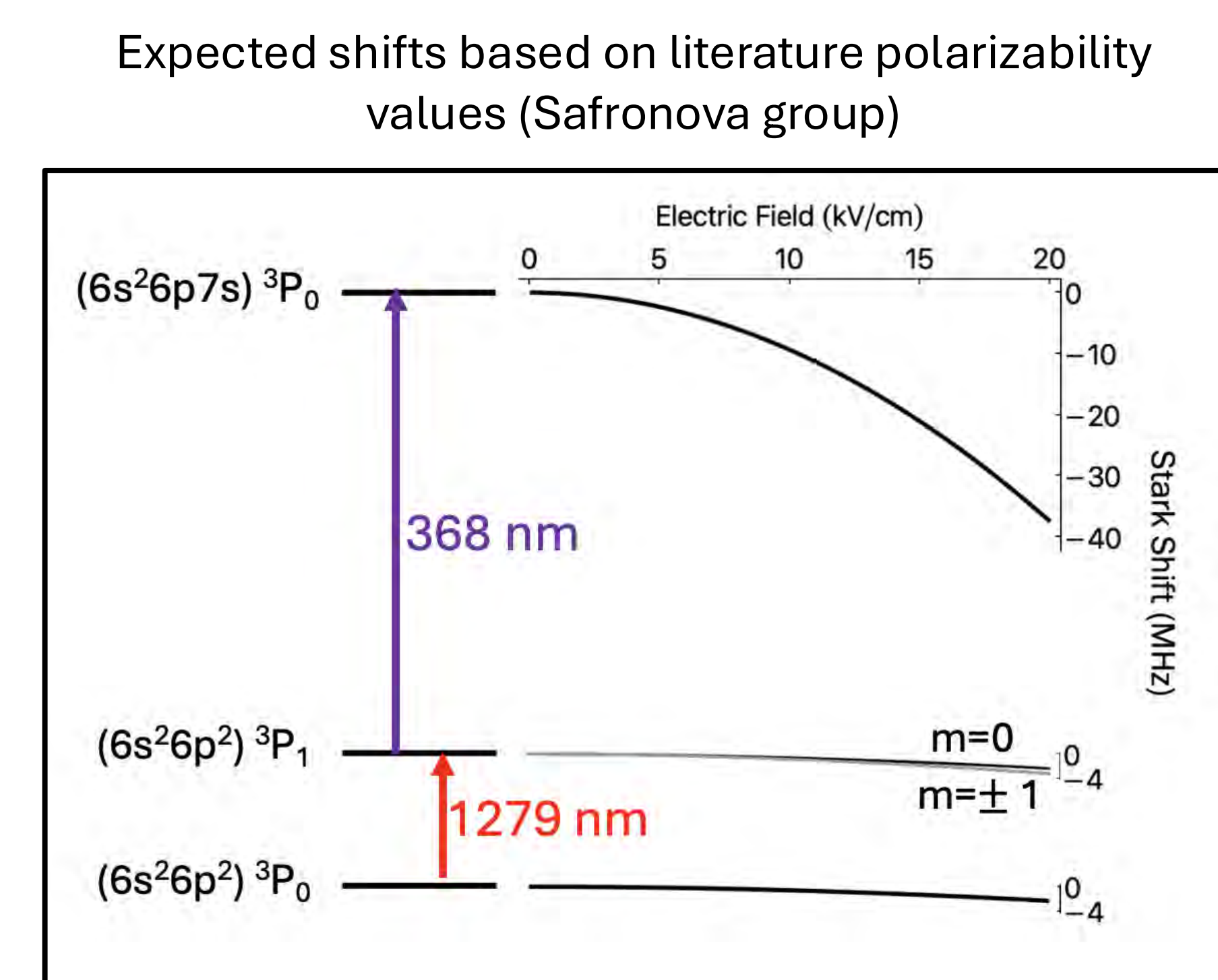

Step 2: Stark-induced amplitude of M1 transition

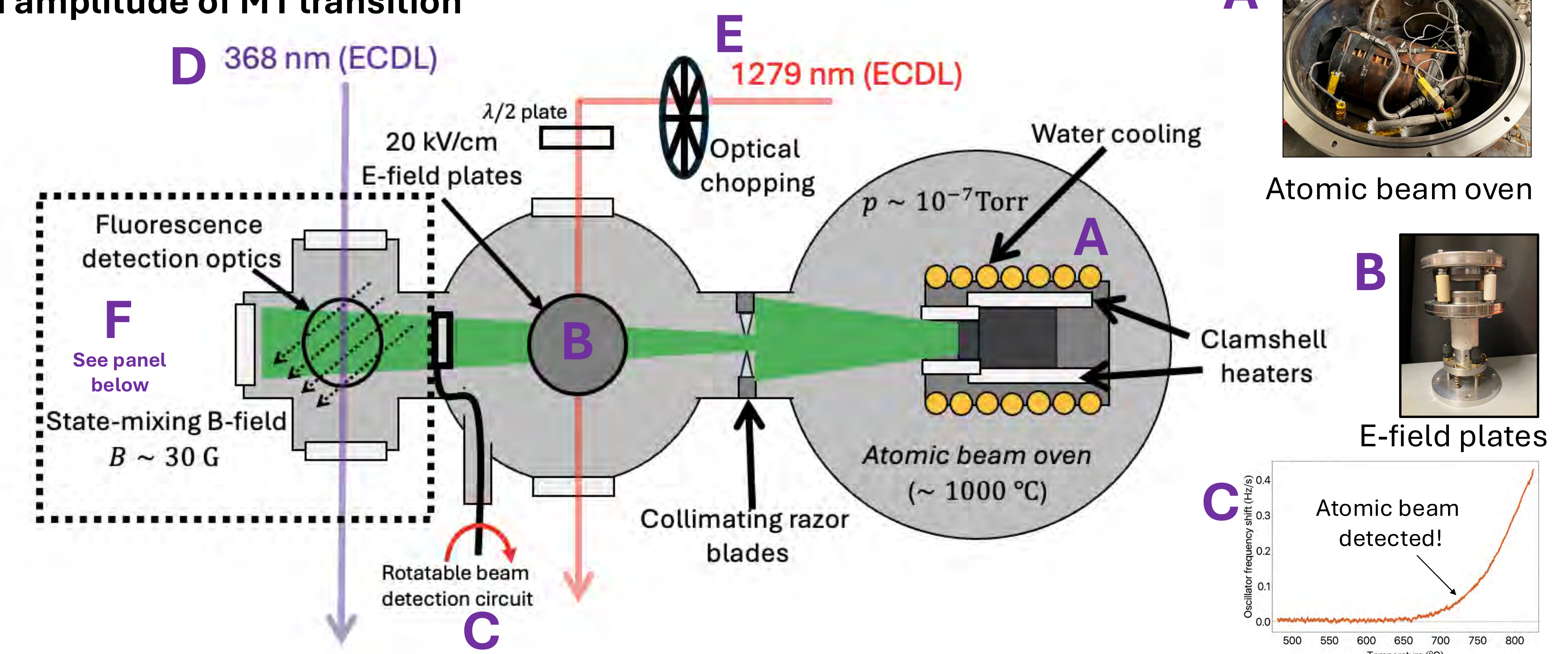
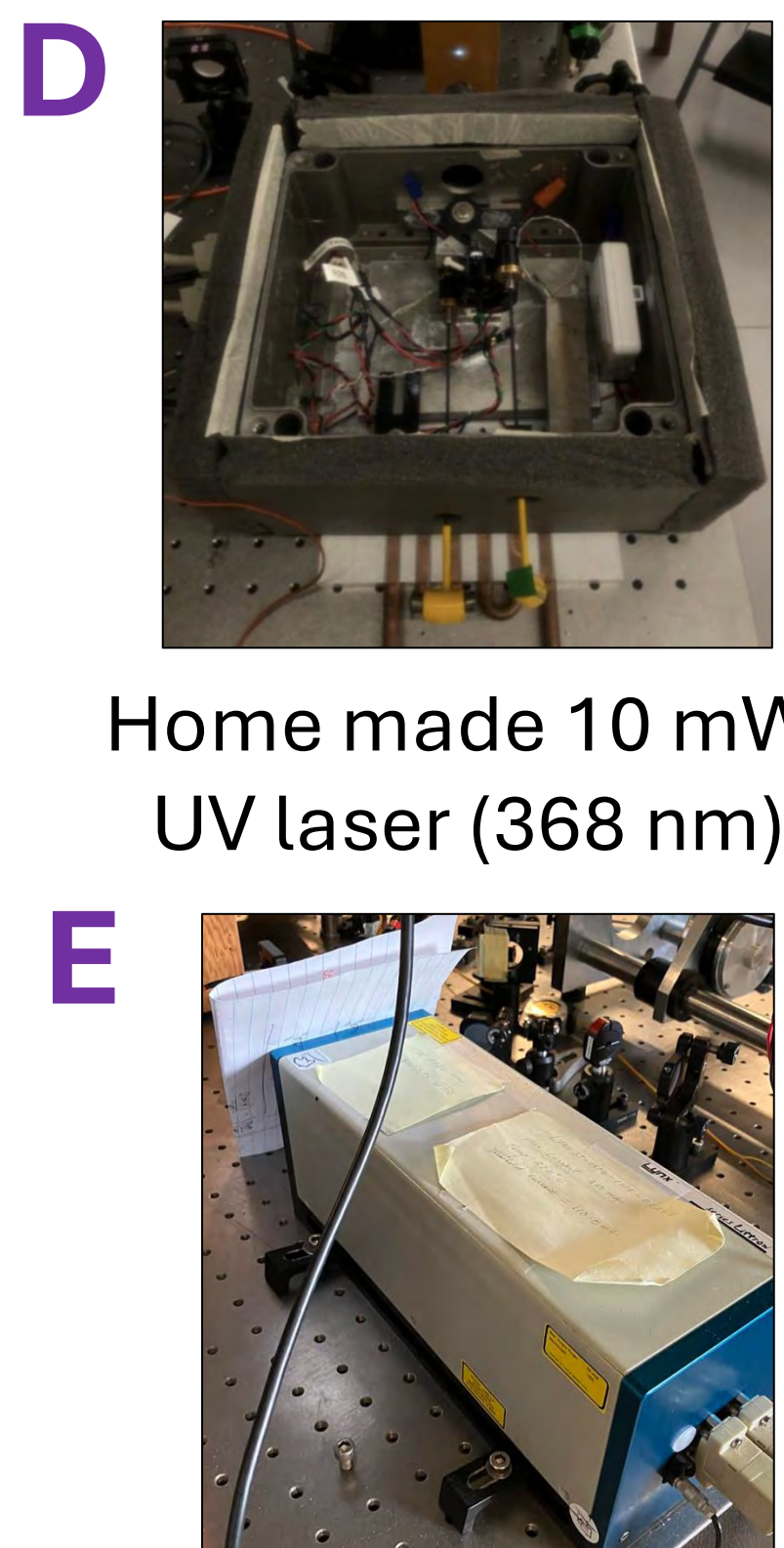

Pierce oscillator detection signal

Future work – Transverse laser cooling of Pb

- Pb-based molecules (CuPb, AuPb, AgPb) offer an exciting new platform for electron EDM measurements.
- A promising candidate is AuPb, which can be formed by associating laser cooled Pb with Au. (K. Stuntz, et al., PHYS. REV. A 110, 042807 (2024))
- The 368 nm E1 transition is a natural choice for optical cycling in Pb. As a type-2 optical cycling transition, ($J = 1 \rightarrow J' = 0$) a state-mixing B field (~ 30 G) is needed to limit dark state population ($(6s^2)^3P_1, m = 0$).
- Cooling parameters**
 - Atomic mass: 208 a.m.u
 - Wavelength: 368.5 nm
 - Lifetime ~ 6 ns
 - Forward beam velocity: ~ 380 m/s
 - Transverse velocity: ~ 5 m/s
 - Multi-pass arrangement
 - No. photons to reach Doppler limit: ~ 1000

Step 3: Transverse laser cooling of Pb

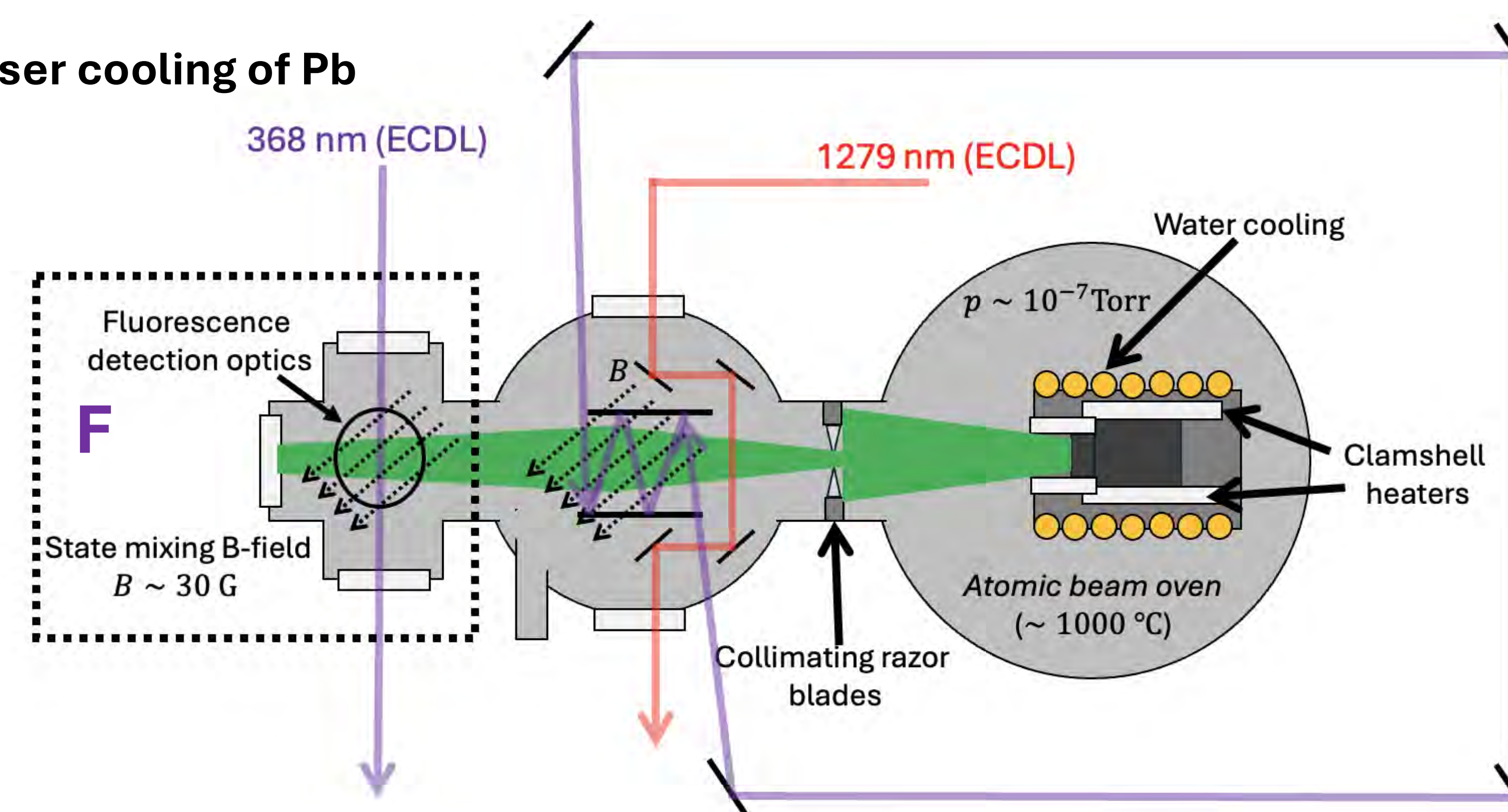
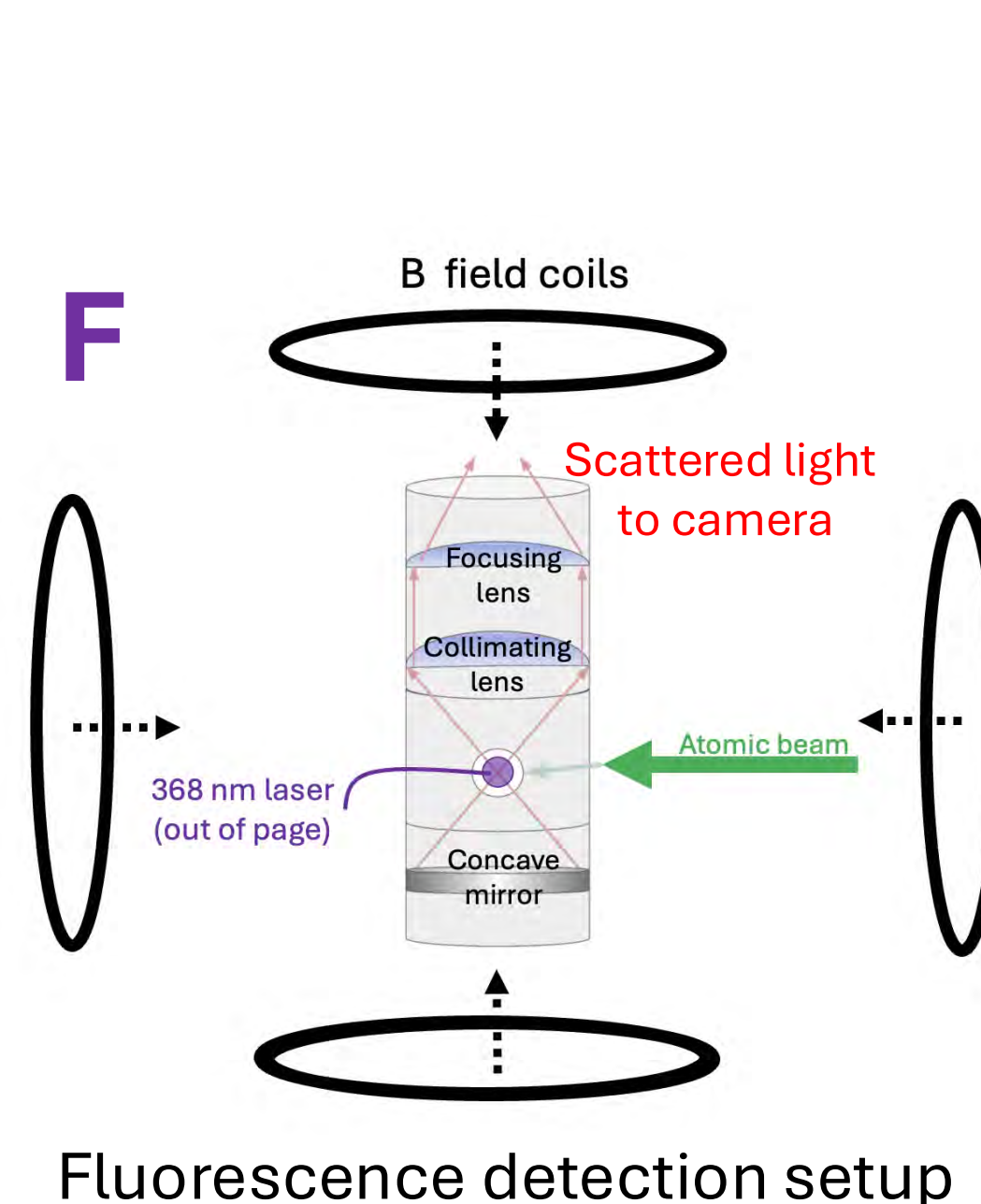

G Ti:Sapph producing 736 nm light (750-1000 mW)

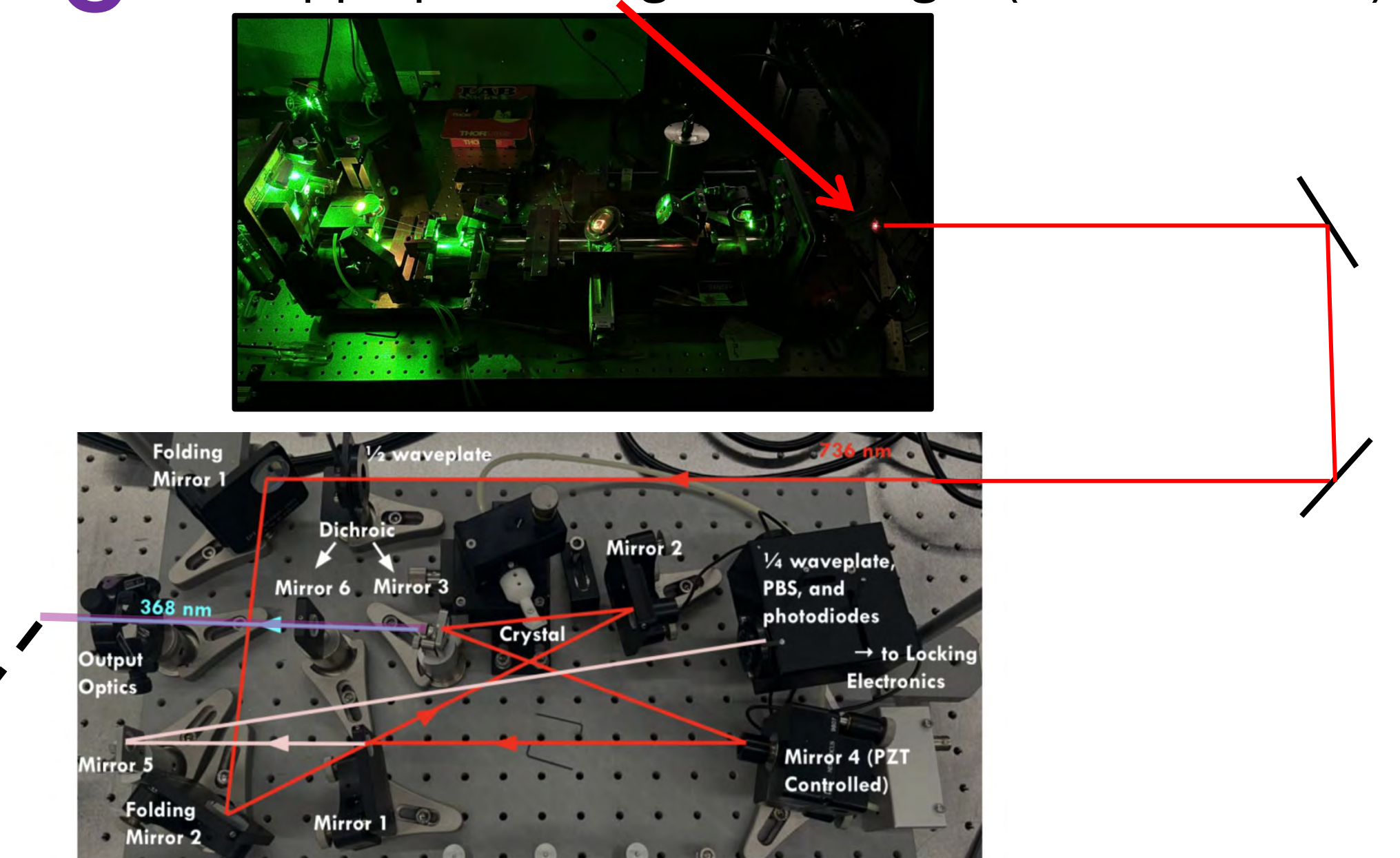

368 nm (f-doubled Ti : Sapph)